

**DRUK GREEN POWER CORPORATION LIMITED
MATERIAL MANAGEMENT SECTION
PHUENTSHOLING: BHUTAN**



STANDARD BIDDING DOCUMENT

SUPPLY AND DELIVERY OF SHIMS AND PRESSURE GAUGES

**NIT No. MMS0074/2023, Date: 17/04/2024
File No. DGPC/MMS/Shims & Pressure Gauges/2024/375**

These documents are meant for the exclusive purpose of bidding against this NIT and shall not be transferred, reproduced or otherwise used for purposes other than that for which they are specifically issued.



27/04/2024

TABLE OF CONTENTS

1	SCOPE OF SUPPLY.....	2
2	DOCUMENTS COMPRISING BID	2
3	BID PRICE	2
4	TAXES AND DUTIES	2
5	BID VALIDITY.....	3
6	BID SECURITY.....	3
7	SUBMISSION OF BIDS.....	4
8	BID OPENING	4
9	EVALUATION OF BID.....	4
10	RIGHT TO ACCEPT OR REJECT BIDS.....	5
11	QUANTITY VARIATION	5
12	AWARD OF CONTRACT	5
13	DELIVERY SCHEDULE.....	5
14	PERFORMANCE SECURITY	5
15	RETENTION MONEY	6
16	LIQUIDATED DAMAGE	6
17	FORCE MAJEURE	6
18	PAYMENT TERMS	6
19	WARRANTY PERIOD.....	7
20	TERMINATION	7
21	GOVERNING LAW	7
22	DISPUTE RESOLUTION	8
	PRICE SCHEDULE.....	9
	BID SUBMISSION FORM.....	10
	CONTRACT AGREEMENT	12

NOTICE INVITING TENDER

NIT No. MMS0073/2024

Date: 17/04/2024

Material Management Section (MMS), Druk Green Power Corporation Limited invites eligible domestic bidders to submit sealed bid for the supply and delivery of **Shims and Pressure Gauges** as per the following Terms and Conditions:

TERMS AND CONDITIONS

1 Scope of Supply

- 1.1 The scope of supply under this invitation shall be as per the Technical Specification and Price Schedule attached to this Bidding Document.
- 1.2 The bidder(s) can obtain further information and clarifications in writing from **Miss Pema Choki**, email p.choki3561@drukgreen.bt not later than **(Five Days)** from the date of bid submission.

2 Documents comprising Bid

- 2.1 The bid must be accompanied by the following documents:
 - a) Bid Security
 - b) Bid Submission Form
 - c) Valid Trade License
 - d) Latest Tax Clearance
 - e) Price Schedule
 - f) Power of Attorney (if applicable)

3 Bid Price

- 3.1 All prices shall be quoted in **BTN**. The quoted price shall be firm during the entire period of the performance of the contract and shall not be subject to variation on any account unless otherwise specified by Purchaser in the Bid Documents.
- 3.2 The final place of delivery is **CIP, MMS Stores, DGPC, Phuentsholing, Bhutan**.
- 3.3 The bidder(s) may quote for any or all items under this invitation. Each item shall be evaluated and contract awarded separately to the firm(s) offering the lowest evaluated price for each item.

4 Taxes and Duties

- 4.1 For Goods manufactured outside Bhutan, the Supplier shall bear and pay all applicable taxes, stamp duties, license fees and other similar levies imposed outside Bhutan as applicable in line

with the Incoterms. Any domestic taxes, duties and any other levies imposed on import of goods into Bhutan, except TDS, shall be borne and paid by the Purchaser.

- 4.2 For Goods manufactured or supplied by the Suppliers from the Kingdom of Bhutan, the Supplier shall bear all applicable taxes, duties, license fees and other similar levies incurred until delivery of the contracted Goods to the Place of Delivery.
- 4.3 Bidders participating from India and supplying materials and services from within India for bonafide use in the Kingdom of Bhutan shall quote the rates for the items in the Price Schedule exclusive of any effect of Indian Goods and Service Tax (IGST). The IGST on the export of goods and services or both are covered under Zero Rated Supply as per Chapter VII, 16(1) of the INTEGRATED GOODS AND SERVICES TAX ACT, 2017 of India.
- 4.4 At the time of release of payment, Tax Deducted at Source (TDS) for Bhutanese Suppliers shall be 2%. TDS shall be deducted by the Purchaser from the gross amount of contract. The Purchaser shall furnish necessary TDS Certificate to the Suppliers.

5 Bid Validity

- 5.1 The bid shall be valid for **60 days** from date of bid submission, i.e., up to **13/07/2024** from the date of submission of the bid. In exceptional circumstances, prior to the expiration of the bid validity period, the Purchaser may solicit the Bidder's consent to an extension of the bid validity period. The request and responses shall be made in writing. A bid valid for a shorter period shall be considered non-responsive.

6 Bid Security

- 6.1 The bid shall be accompanied by the bid security of **BTN 21,000.00** in the form of Cash Warrant/Unconditional Bank Guarantee/Banker Cheque/Demand draft in the name of Material Management Division, Druk Green Power Corporation Limited issued by the Financial Institution enforceable in any Banks in Bhutan.
 - a) The Bid security shall be valid up to **12/08/2024**
 - b) The Bid Security is to be submitted as a part of the Bid.
 - c) Any Bid not accompanied by bid security of adequate value and validity shall be rejected by the Purchaser as non-responsive.
- 6.2 The bid security shall be forfeited in the following cases:
 - a) If the Bidder withdraws the bid after Bid opening during the period of Bid validity.
 - b) If the Bidder does not accept the correction of the Bid price;
 - c) In the case of a successful bidder, if the bidder fails within the specified time limit to sign the Contract or furnish Performance Security.

7 Submission of Bids

- 7.1 The bidder(s) shall submit one original bid and clearly marked ORIGINAL. The bid including all documents should be duly filled, signed and sealed in an envelope and addressed to and delivered at the following address.

Name: **Sangay Pema**

Designation: **Head**

Address: **Material Management Section, Phuentsholing, Bhutan**

Telephone: 05-254465

E-mail: s.pema1815@drukgreen.bt

The bid shall contain the NIT reference and date including the date of opening. The same should be clearly mentioned on the outer envelope.

- 7.2 Alternatively, bid including all documents duly filled, signed and sealed/stamped may be submitted electronically with pass word protection at the following address: **[NOT APPLICABLE]**
- 7.3 The deadline for receipt of your bid(s) by the Purchaser shall be at **14/05/2024 at 15:00 hrs.**
- 7.4 The Bidder shall submit the Bid Submission Form using the Form attached in this Bidding Document. This form must be completed without any alterations to its format, and no substitutes shall be accepted. All blank spaces shall be filled in with the information requested.
- 7.5 A bid in which the Bid Submission Form is not duly filled, signed and sealed by the bidder shall be rejected.

8 Bid Opening

- 8.1 The bid(s) will be opened in the presence of bidders or their authorized representatives who choose (not more than two representatives) to attend at **14/05/2024 at 15:30hrs. MMD Office.** In case, due date of the opening of the bid falls on non-working day, the opening of the bid shall be on the next working day at the same time.

9 Evaluation of Bid

- 9.1 Bids determined to be substantially responsive to the technical specifications and commercial conditions shall be evaluated by comparison of their quoted prices. In evaluating the bids, the Purchaser shall determine for each bids the evaluated price by adjusting the priced bid by making any correction for any arithmetical errors as follows;
- where there is a discrepancy between amounts in figures and in words, the amount in words shall govern;
 - where there is discrepancy between the unit rate and the line-item total resulting from multiplying the unit rate by the quantity, the unit rate as quoted shall govern unless in the opinion of the Purchaser there is an obviously gross misplacement of the decimal point

in the unit rate, in which case the line-item total as quoted shall govern, and the unit rate shall be corrected.

- 9.2 To assist in the evaluation and comparison of the Bids, the Purchaser may, at its discretion, ask any Bidder for a clarification of its Bid. Any clarification submitted by a Bidder that is not in response to the request by the Purchaser shall not be considered.

10 Right to Accept or Reject Bids

- 10.1 The Purchaser is not bound to accept the lowest bid and reserves the right to accept or reject any or all the bids without assigning any reason whatsoever.

11 Quantity Variation

- 11.1 Depending on the final requirement, at the time of the award of the Contract, the Purchaser may increase or decrease the quantities by twenty five percent (25%) of the total quantity of the item without any change in the unit prices or other terms and conditions of the Bid and the Bidding Document.

12 Award of Contract

- 12.1 The Purchaser shall award the Contract to the Bidder whose offer has been determined to be the lowest evaluated Bid meeting the specifications. The Purchaser shall issue Notification of Award/Purchase Order to the successful Bidder. The successful bidder shall sign a contract as per the format attached to this Bidding Document. Until a formal Contract is executed, the Notification of Award shall constitute a binding Contract.

13 Delivery Schedule

- 13.1 The supply of the Goods and related service shall be completed within **90** days from the date of issue of the Notification of Award/Purchase Order.

14 Performance Security

- 14.1 If the contract value is above Nu. 0.50 Million prior to signing of contract, the Supplier shall be required to furnish Performance Security of 10% of the contract price in the form of cash warrant, demand draft or unconditional Bank Guarantee in the name **Material Management Division, Druk Green Power Corporation Limited** issued by a financial institution enforceable in any Banks in Bhutan, which shall be furnished upon issuance of notification of the award. Performance Security shall be valid till the end of warranty period and shall be returned after the end of warranty period. Under exceptional circumstances, if submission of Performance Security in the above forms is not possible, the Supplier shall be allowed to deposit Performance Security in the form of cash deposit through bank transfer.

15 Retention Money

- 15.1 In case of contract value up to BTN 0.50 million, 10% of payment shall be retained as security deposit and shall be returned at the end of the warranty period.
- 15.2 Retention money will not be application for the item without warranty period. However, in case of part supply, 10% of the invoiced amount will be kept as retention money until the execution of full supply of goods in good condition.

16 Liquidated Damage

- 16.1 If the Supplier fails to deliver any or all of the Goods by the date(s) of delivery or fails to perform the related Services within the period specified in the Contract/Purchase Order, the Purchaser shall deduct Liquidated Damages at the rate of **0.3%** per day for each day of delay to a maximum of 10% (Ten) percentage of the total value of delayed goods or unperformed services.

In case of delay for supply of an item which can be made in parts, but the item cannot be put to use unless the supplies are complete, the liquidated damage shall be levied up to the maximum 10% of the Contract Price.

17 Force Majeure

- 17.1 The Supplier shall not be liable for forfeiture of its Performance Security/Retention Money, liquidated damages or termination for default if and to the extent that it's delays in performance or other failure to perform its obligations under the Contract is the result of an event of Force Majeure.
- 17.2 For purposes of this Clause, "Force Majeure" means an event or situation beyond the control of the Supplier that is not foreseeable, is unavoidable, and its origin is not due to negligence or lack of care on the part of the Supplier. Such events may include, but not be limited to, war, civil insurrection, fire, floods, epidemics, earthquakes, quarantine restrictions and freight embargoes.
- 17.3 If a Force Majeure situation arises, the Supplier shall promptly notify the Purchaser in writing of such condition and the cause thereof. Unless otherwise directed by the Purchaser in writing, the Supplier shall continue to perform its obligations under the Contract as far as is reasonably practical, and shall seek all reasonable alternative means for performance not prevented by the Force Majeure event.

18 Payment Terms

- 18.1 The Contract Price, including any advance payments, if applicable, shall be paid as under:

100% payment shall be made within 30 (thirty) days from the date of receipt of materials and complete submission of shipping/delivery documents. Bank charges for payment, if any, shall be deducted from the purchaser's account.

- 18.2 Payments shall be made promptly by the Purchaser, no later than thirty (30) days after the receipt of invoices and documents, provided that the documents are compliant with all the requirements of the Purchaser. In case of incomplete/ non-compliant invoices and documents, the Purchaser shall ask the Supplier to re-submit the invoices and documents with full compliance.
- 18.3 At the time of release of payment, Tax Deducted at Source [TDS] from the gross amount of bills shall be as per the Income Tax Act of the Bhutan. The Purchaser shall furnish necessary TDS Certificate to the Suppliers.

19 Warranty Period

- 19.1 The Supplier shall provide the warranty for a period of **365 days**, for the goods to be supplied and confirm that if any faults are detected within the warranty period in the supplied/installed Goods, the Supplier shall be bound to rectify the fault or replace the Goods as the case may be. The performance security shall be used to cover the cost of supplies not delivered or defective items not replaced or rectified. **[IF APPLICABLE]**
- 19.2 Any goods found defective during the warranty period shall be replaced/repared by the supplier at his cost. If the supplier fails to rectify and or replace the defective goods, the Purchaser shall do it at the cost of the supplier.

20 Termination

- 20.1 The Purchaser may, by written notice, terminate the Purchase Order or Contract [if applicable] in whole or in part at any time for its convenience under following cases:
- If the Supplier fails to perform any other terms and conditions specified with the Purchase Order/ Contract, or exceeds the maximum amount of Liquidated Damages; or
 - If the Supplier fails to perform any other obligation(s) under the Purchase Order/Contract, and if the Supplier does not take any remedial action within a period of **30 days** after receipt of a notice of default from the Purchaser specifying the nature of the default(s); or
 - If the Supplier, in the judgment of the Purchaser, has engaged in any corrupt or fraudulent practices in competing for or in executing the tasks under this Purchase Order.

21 Governing Law

- 21.1 The Contract shall be governed by and interpreted in accordance with the Laws of the Kingdom of Bhutan.

22 Dispute Resolution

- 22.1 The Purchaser and the Supplier shall make every effort to resolve amicably by direct informal negotiation of any disagreement or dispute arising between them under or in connection with the contract. If the parties fail to resolve such a dispute or difference by mutual consultation within 30 days from commencement of such consultation, either part may require that the dispute be referred for resolution to the formal mechanisms as specified hereunder.
- 22.2 Any dispute, controversy or claim arising out of or relating to this contract, or breach, termination or invalidity thereof, that could not be resolved through amicable negotiation, shall be settled by arbitration in accordance with the Alternative Dispute Resolution Act of Bhutan 2013 for Bhutanese Supplier and the United Nations Commission on International Trade Law [UNCITRAL] Arbitration Rules of 1976 for International Supplier.

PRICE SCHEDULE

As per Price Schedule Attached

TECHNICAL SPECIFICATION OF THE GOODS REQUIRED (if any)

SN	Item	Description & Details (minimum specifications of goods to be supplied)
1		
2		
3		
4		
5		
6		
7		
8		
9		
10		

The Supplier is required to mention make/model (as applicable) of the goods to be supplied and must attach the appropriate original printed literature/brochures for the various items listed.

Signature of Supplier:	Supplier's Official Stamp
Name of Supplier:	
Date:	

BID SUBMISSION FORM

[The Bidder shall fill in this form in accordance with the instructions indicated. No alterations to its format shall be permitted and no substitutions shall be accepted.]

Date: 17/04/2024

Tender No.: MMS0074/2024

To
Head, Material Management Section (MMS)
Druk Green Power Corporation Limited (DGPC)
Phuentsholing, Bhutan

Dear Sir,

We, the undersigned, declare that:

- (a) We have examined and have no reservations to the Bidding Documents, including Addenda number..... *[insert the number and date of issue of each addendum]*;
- (b) We offer to supply in conformity with the Bidding Documents and in accordance with the Schedule of Supply the following Goods and Related Services: *[insert a brief description of the Goods and Related Services]*;
- (c) The total price of our Bid, excluding any discounts offered in item is: *[insert the Bid Price in words and figures, indicating the various amounts and their respective currencies]*;
- (d) The discounts offered and the methodologies for their application are:
Discounts. If our Bid is accepted, the following discounts shall apply: *[Specify in detail each discount offered and the specific item of the Schedule of Supply to which it applies.]*
Methodology of Application of the Discounts. The discounts shall be applied using the following methodology: *[Specify in detail the methodology that shall be used to apply the discounts]*;
- (e) Our Bid shall be valid for a period of *[insert number]* from the date fixed for the Bid submission deadline and it shall remain binding upon us and may be accepted at any time before expiry of that period;
- (f) If our Bid is accepted, we commit to provide a Performance Security in accordance with Clause 15 for the due performance of the Contract;
- (g) We, including any subcontractors or suppliers for any part of the Contract, have nationality from eligible countries, viz: *[insert the nationality of the Bidder, including that of all parties that comprise the Bidder if the Bidder is a JV/ Consortium, and the nationality each subcontractor and supplier]*
- (h) We have no conflict of interest;
- (i) Our firm, its affiliates or subsidiaries - including any subcontractors or suppliers for any part of the contract - has not been declared ineligible by the Purchaser under the laws or official regulations of Bhutan;
- (j) We have read the terms and conditions carefully, understood and agree to comply with all the clauses which are mentioned therein. In case of any breach of any condition on our part, we shall be liable for actions as per terms and conditions of the Contract;

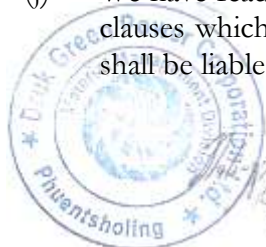

- (k) We understand that this Bid, together with your written acceptance thereof included in your notification of award, shall constitute a binding contract between us, until a formal contract is prepared and executed;
- (l) We understand that you are not bound to accept the lowest evaluated Bid or any other Bid that you may receive; and
- (m) We accept the Vendor Performance Management System.

Thanking you.

Yours sincerely,

Signed: *[insert signature of person whose name and capacity are shown]*

In the capacity of *[insert legal capacity of person signing the Bid Submission Form]*

Name: *[insert complete name of person signing the Bid Submission Form]*

Duly authorized to sign the bid for and on behalf of: *[insert complete name of Bidder]*

Dated on _____ day of _____ *[insert date of signing]*



CONTRACT AGREEMENT

[The successful Bidder shall fill in this form in accordance with the instructions indicated]

THIS CONTRACT AGREEMENT made the *[insert number]* day of *[insert month]*, *[insert year]*,

BETWEEN

- 1) *[insert complete name of Purchaser]*, a *[insert description of type of legal entity, for example, an agency of the Ministry of of the Government of Bhutan, or corporation incorporated under the laws of Bhutan]* and having its principal place of business at *[insert address of Purchaser]* (hereinafter called “the Purchaser”), and
- 2) *[insert name of Supplier]*, a corporation incorporated under the laws of *[insert: country of Supplier]* and having its principal place of business at *[insert: address of Supplier]* (hereinafter called “the Supplier”).

WHEREAS the Purchaser invited Bids for certain Goods and ancillary services, viz., *[insert brief description of Goods and Services]* and has accepted a Bid by the Supplier for the supply of those Goods and Services in the sum of *[insert Contract Price in words and figures, expressed in the Contract currency(ies)]* (hereinafter called “the Contract Price”).

NOW THIS AGREEMENT WITNESSETH AS FOLLOWS:

- 1) In this Agreement words and expressions shall have the same meanings as are respectively assigned to them in the Conditions of Contract referred to.
- 2) The following documents shall constitute the Contract between the Purchaser and the Supplier, and each shall be read and construed as an integral part of the Contract, viz.:
 - a) This Contract Agreement;
 - b) Terms and Conditions;
 - c) Technical Requirements (including Price Schedule and Technical Specifications);
 - d) The Supplier’s Bid and original Price Schedules;
 - e) The Purchaser’s Notification of Award of Contract;
 - f) The Performance Security (*where applicable*);
 - g) *[insert here any other document(s) forming part of the Contract]*
- 3) This Contract shall prevail over all other Contract documents. In the event of any discrepancy or inconsistency within the Contract documents, then the documents shall prevail in the order listed above.
- 4) In consideration of the payments to be made by the Purchaser to the Supplier as hereinafter mentioned, the Supplier hereby covenants with the Purchaser to provide the Goods and Services and to remedy defects therein in conformity in all respects with the provisions of the Contract.
- 5) The Purchaser hereby covenants to pay the Supplier in consideration of the provision of the Goods and Related Services and the remedying of defects therein, the Contract Price or such



other sum as may become payable under the provisions of the Contract at the times and in the manner prescribed by the Contract.

6)

IN WITNESS whereof the parties hereto have caused this Agreement to be executed in accordance with the laws of Bhutan on the day, month and year indicated above.

For and on behalf of the Purchaser Signed: *[insert signature]*
in the capacity of *[insert title or other appropriate designation]*

in the presence of *[insert signature]*
[insert identification of official witness]

For and on behalf of the Supplier
Signed: *[insert signature of authorized representative(s) of the Supplier]*
in the capacity of *[insert title or other appropriate designation]*

in the presence of *[insert signature]*
[insert identification of official witness]



PRICE SCHEDULE

SN	Material Code	Material Description	Qty.	UoM	Unit Rate (BTN)		Total Amount (Nu.)	Make/Brand	Country of Origin
					Figure	Words			
1	2000002656 EMCIPGPG	Pressure gauge, 0-4kg/cm2, 100x20x1.5mm, 0-4 - Pressure Ranges. 100 – Dia meter of pressure gauge. 20 - connection size 20 mm. 1.5 - Metric thread size 1.5 mm	12	NO				Wika/ Equivalent/ Higher	
2	2000002644 EMCIPGPG	Pressure gauge, 0-10kg/cm2, 150mm, M20, 0-10 - pressure Ranges. 150 - Diameter of pressure gauges. M20 - Connection size 20 mm thread/pitch size - 1.5mm	7	NO				Wika/ Equivalent/ Higher	
3	2000010816 EMCISHSH	CCW pump SS shim (2mm)	15	NO				Suntech/ Equivalent/ Higher	
4	2000010817 EMCISHSH	CCW pump SS shim (1mm)	15	NO				Suntech/ Equivalent/ Higher	
5	2000010818 EMCISHSH	CCW pump SS shim (0.5mm)	15	NO				Suntech/ Equivalent/ Higher	
6	2000010819 EMCISHSH	CCW pump SS shim(0.3mm)	15	NO				Suntech/ Equivalent/ Higher	
7	2000010820 EMCISHSH	CCW pump SS shim (0,25mm)	15	NO				Suntech/ Equivalent/ Higher	
8	2000010821 EMCISHSH	CCW pump SS shim (0.2mm)	15	NO				Suntech/ Equivalent/ Higher	



 27/04/2019

SN	Material Code	Material Description	Qty.	UoM	Unit Rate (BTN)		Total Amount (Nu.)	Make/Brand	Country of Origin
					Figure	Words			
9	2000010822 EMCISHSH	CCW pump SS shim (0.15mm)	15	NO				Suntech/ Equivalent/ Higher	
10	2000010823 EMCISHSH	CCW pump SS shim (0.1mm)	15	NO				Suntech/ Equivalent/ Higher	
11	2000018708 EMSTTUTU	Hard Nylon Rod, Dia 100mm x 500mm	1	NO				Make to be specified	
12	2000018709 EMSTTUTU	Soft Nylon Rod, Dia 100mm x 500mm	1	NO				Make to be specify	
13	2000011469 EMCIPGPG	SS bourden tube pressure gauge DN100,0-60bar	4	NO				Make to be specify	
14	2000011174 EMCIPGPG	Pressure Gauge 212-20-100 Dial size:10mm, Range: 0-60 Kg/cm sq, Accuracy: 1.6% of FS, Movement: Stainless Steel Connection: 1/4" BSP	2	NO				Wika/ Equivalent/ Higher	
15	2000009400 EMCIPGPG	Stainless steel bourden tube pressure, gauge, version model#233.50, 0-10bar, (100 x 49.5), thread size G1/2B (Major diameter 20.95, pitch -1.814mm, thread per inch -14)	4	NO				Wika/ Equivalent/ Higher	
16	2000012589 EMCIPGPG	Pressure gauge NG63.213.53.63 KL.1.6, Gly. filled. 0-10bar NS 63 [2 1/2"], Centre back mount, G 1/4 B (Detail attached as Annexure I)	1	NO				Wika Equivalent/ Higher	
17	2000008036 EMVASVSV	DCV, 5/2 way pilot operated, 2M/1704/33	4	NO				Make to be specify (Submit Catalogue)	



SN	Material Code	Material Description	Qty.	UoM	Unit Rate (BTN)		Total Amount (Nu.)	Make/Brand	Country of Origin
					Figure	Words			
18	2000002619 EMCIPGPG	Pressure gauge, 0-7 kg/cm ² , 100 mm dia, Glycerene filled,	30	NO				H.Guru/ Equivalent/ Higher	
19	2000012919 EMCIGAGA	Rubber Gasket sheet, 2 mm	2	ROL				Champion/ Equivalent/ Higher	
20	2000012920 EMCIGAGA	Rubber Gasket sheet, 3 mm	4	ROL				Champion/ Equivalent/ Higher	
21	2000012922 EMCIGAGA	Rubber Gasket sheet, 5 mm	2	ROL				Champion/ Equivalent/ Higher	
22	2000012921 EMCIGAGA	Rubber Gasket sheet, 4 mm	2	ROL				Champion/ Equivalent/ Higher	
23	2000018587 EMCIPGPG	Nitrogen Testing Pressure Guage,0-27 Mpa Inlet Adaptor 1"	1	NO				Wika/ Equivalent/ Higher	
24	2000018520 EMCIPGPG	Uplift Pressure Meter (Gauge)	5	NO				Wika/ Equivalent/ Higher	
25	2000018549 EMCIPGPG	Pressure Gauge, 0-100 PSI,0-7 Kg/sq.cm	2	NO				Wika/ Equivalent/ Higher	
26	2000002619E MCIPGPG	Pressure gauge, 0-7 kg/cm ² , 100 mm dia	16	NO				Wika/ Equivalent/ Higher	
27	2000014896E MCIGAGA	champion Gasket,4mm thickness,1.2m width	6	ROL				Champion/ Equivalent/ Higher	



SN	Material Code	Material Description	Qty.	UoM	Unit Rate (BTN)		Total Amount (Nu.)	Make/Brand	Country of Origin
					Figure	Words			
28	2000014895E MCIGAGA	champion Gasket,3mm thickness,1.2m width	5	ROL				Champion/ Equivalent/ Higher	
29	2000010914 EMCISHSH	S.S Shim 0.12mm with 600mm	12	M				Ladhani/ Equivalent/ Higher	
30	2000011166 EMCIPGPG	Pr. guage with transmitter, 0-50kg/cm2, 150mm dia, M20. analog output: 0-20mA, 2 conductor, digital display. Supply voltage 24V DC	4	NO				Wika/ Equivalent/ Higher	
31	2000018966 EMSTSHSH	Transparent Size (2400x1200x4)mm, Trasparent Unbreakable Polycarbonate Solid Sheet	2	NO				Make to be specify	
32	2000007638 EMCIPGPG	Pr. Gauge(gly.fill)0-200kg/cm2, H-mount,	10	NO				Fiebig/ Equivalent/ Higher	
33	2000007639E MCIPGPG	Pr. Gauge(gly.fill)0-200kg/cm2, V-mount,	5	NO				Fiebig/ Equivalent/ Higher	
34	2000007660E MCIPGPG	Pr. Gauge(gly.fill)0-200kg/cm2, V-mount,	5	NO				Fiebig/ Equivalent/ Higher	
35	2000007640E MCIPGPG	Pr. Gauge(gly.fill),0-20kg/cm2, V-mount,	5	NO				Fiebig/ Equivalent/ Higher	
36	2000007641E MCIPGPG	Pr. Gauge(gly.fill),0-20kg/cm2, V-mount,	5	NO				Fiebig/ Equivalent/ Higher	
37	2000008852 EMCIPGPG	Pr. gauge 0-500kg/cm2,100mm dia,	3	NO				Fiebig/ Equivalent/ Higher	



SN	Material Code	Material Description	Qty.	UoM	Unit Rate (BTN)		Total Amount (Nu.)	Make/Brand	Country of Origin
					Figure	Words			
38	2000003256E MCIGAGA	Gasket style 59, 1650x1500x2 mm	1	NO				Champion/ Equivalent/ Higher	
39	2000007693E MCIGAGA	Gasket style 59, 1650x1500x1.5mm	1	NO				Champion/ Equivalent/ Higher	
40	2000007285E MCIGAGA	Gasket style 59, 1650x1500x4mm	1	NO				Champion/ Equivalent/ Higher	
Total Amount in figures:									
Total Amount in words:									



Sl.No.16- Pressure gauge NG63.213.53.63 KL.1.6, Gly. filled. 0-10bar

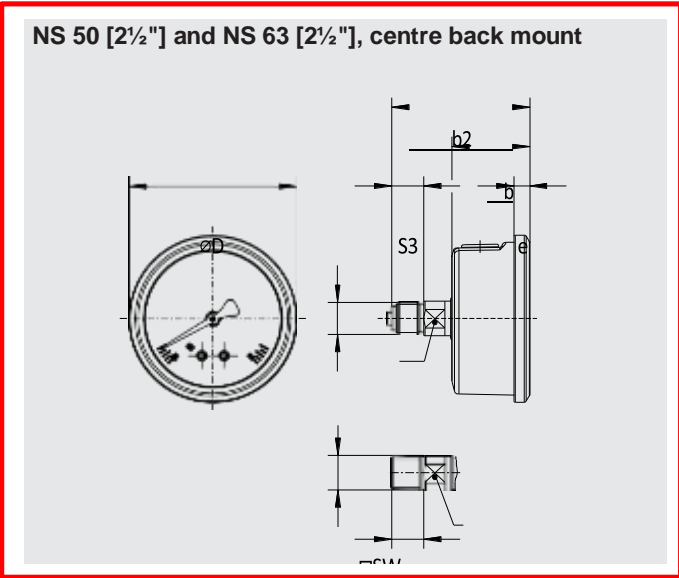

NS	Weight
NS 50 [2"]	0.15 kg [0.33 lb]
NS 63 [2½"]	0.21 kg [0.46 lb]

Process connection with thread per EN 837-1

NS	G	Dimensions in mm [in]					
		$b_2 \pm 0.5$ [0.02]	$b \pm 0.5$ [0.02]	S3	e	D	SW
50 [2"]	G ½ B	52 [2.17]	30 [1.18]	10 [0.39]	5.5 [0.22]	55 [2.17]	14 [0.55]
	G ¼ B	55 [2.17]	30 [1.18]	13 [0.51]	5.5 [0.22]	55 [2.17]	14 [0.55]
	M12 x 1.5	55 [2.17]	30 [1.18]	13 [0.51]	5.5 [0.22]	55 [2.17]	14 [0.55]
63 [2½"]	G ½ B	54 [2.13]	32 [1.26]	10 [0.39]	6.5 [0.26]	68 [2.68]	14 [0.55]
	G ¼ B	57 [2.24]	32 [1.26]	13 [0.51]	6.5 [0.26]	68 [2.68]	14 [0.55]
	M12 x 1.5	57 [2.24]	32 [1.26]	13 [0.51]	6.5 [0.26]	68 [2.68]	14 [0.55]

